

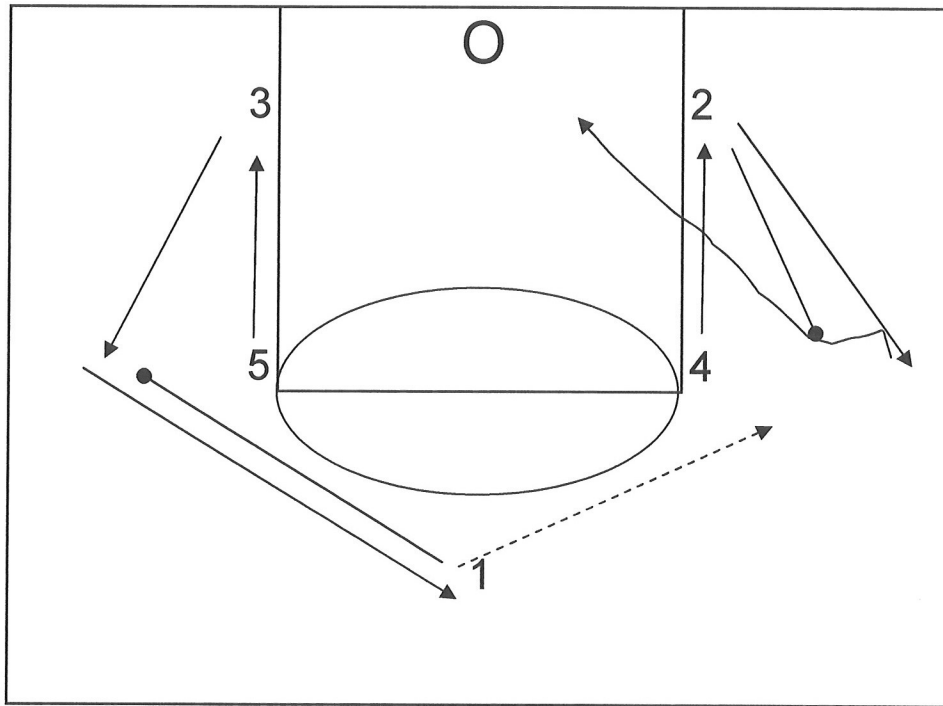



# MOTION SIDE WING PICK



4 AND 5 PICK WINGS ON LOW BLOCKS

2 AND 3 FAKE INSIDE AND BREAK TO WINGS

1 PASS TO 2. GOES OPPOSITE AND PICKS 3 WHO REPLACES 1 ON TOP

4 COMES TO WING AND PICKS FOR 2. 2 DRIVES TO THE BASKET OR HITS 4 ROLLING TO THE BASKET (BOUNCE PASS)

5 SEALS MAN AND REBOUNDS BACK SIDE. 1 LOOKS FOR LONG REBOUND.



## MOTION CROSS SCREEN LOW

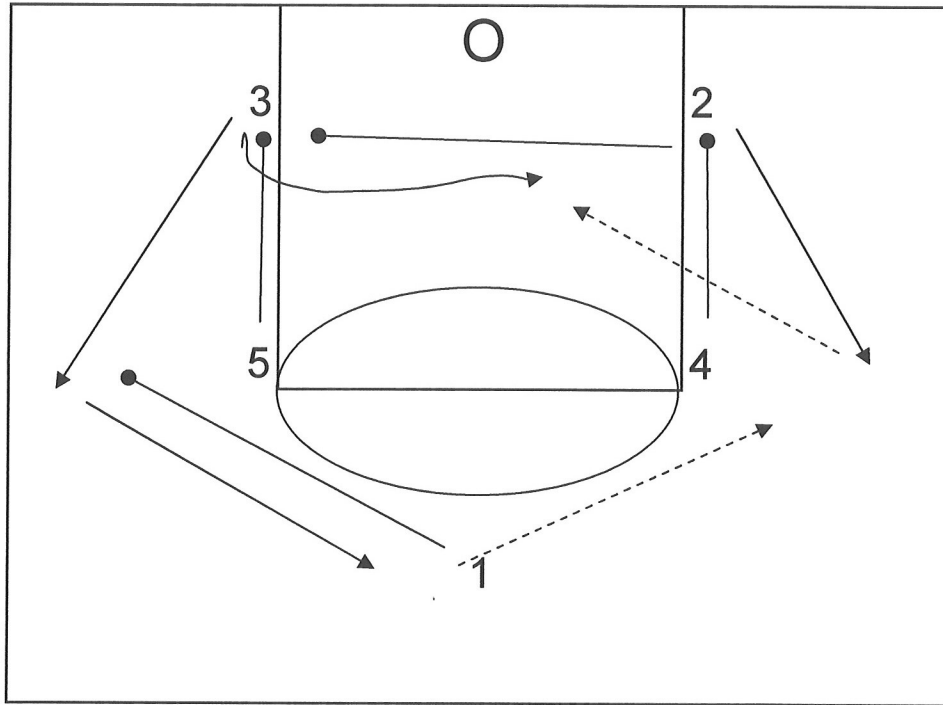

4 AND 5 PICK LOW

1 PASSES TO 2 AND GOES OPPOSITE TO SET PICK FOR 3 WHO REPLACES 1

4 PICKS OPPOSITE LOW BLOCK FOR 5 ( WAIT FOR PICK)

5 BREAKS ACROSS LANE TO BALL SIDE LOW BLOCK.

2 PASSES INSIDE TO 5 CUTTING TO LOW BLOCK

4 SETS PICK AND SEALS FOR BACKSIDE REBOUND

1 LOOKS FOR LONG REBOUND.

# EPYSA OUT OF BOUNDS BASKETBALL PLAYS



## 4 CORNERS PICK AWAY

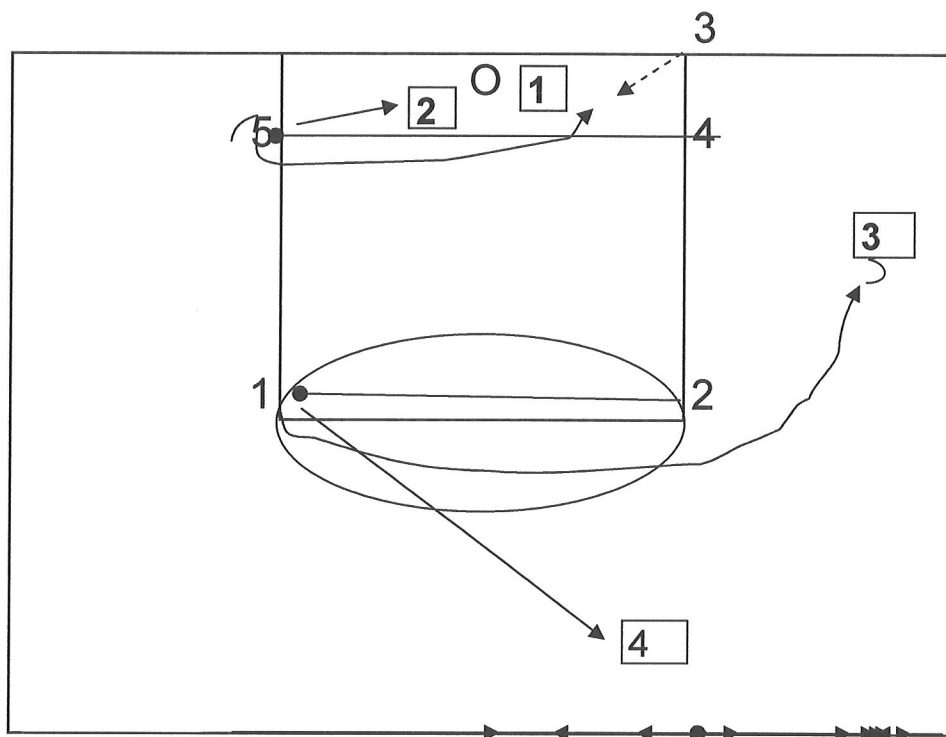

4 AND 2 GO ACROSS THE LANE AND SET PICKS FOR 5 AND 1

5 AND 1 MAKE COME OFF THE PICK

3 WILL LOOK FOR 5 FIRST AND THEN 2 (PER SQUARE BOXES INDICATING PROGRESSION)

# EPYSA OUT OF BOUNDS BASKETBALL PLAYS



## INBOUNDER PICK

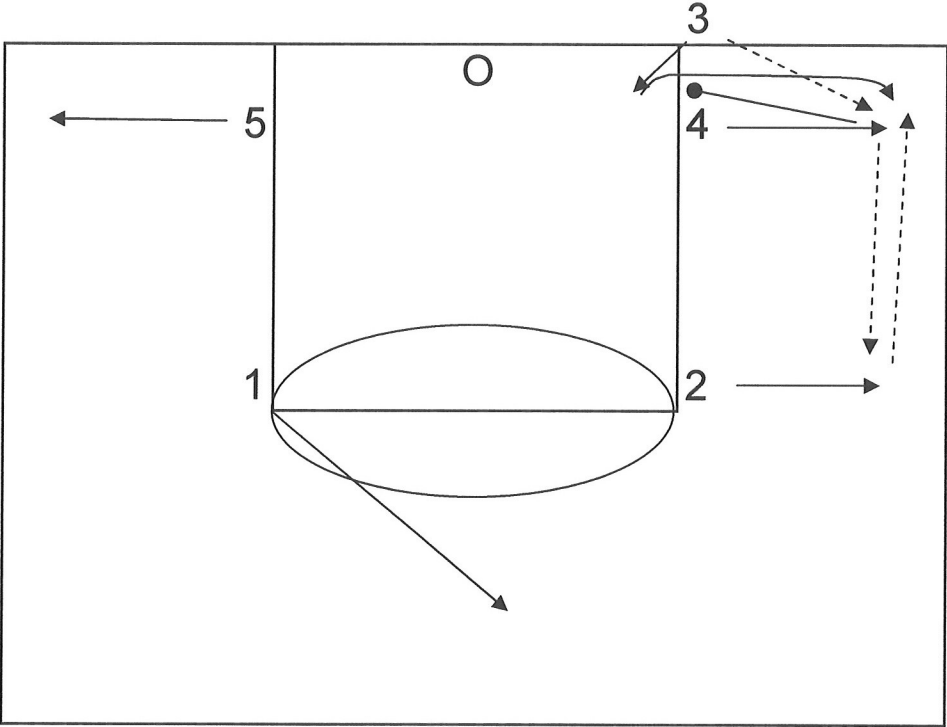

4 WILL FAKE IN AND THEN POP OUT TO THE THREE POINT LINE FOR PASS  
2 WILL POP OUT AND RECEIVE PASS FROM 4  
4 WILL COME IN TOWARDS BASKET TO SET PICK FOR 3  
3 WILL SET HIS MAN UP BY GOING TO THE BASKET THEN POPPING OUT FOR A PASS FROM 2



# PICK THE PICKER

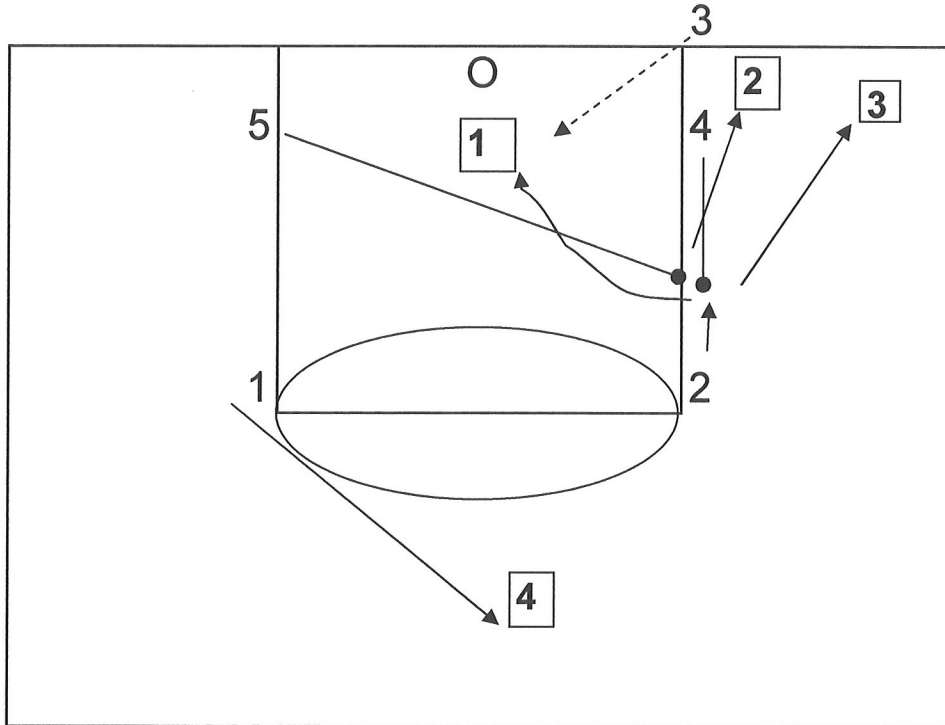

4 WILL PICK FOR 2  
5 WILL COME TO THE ELBOW AND PICK FOR 4  
3 WILL LOOK FOR 4 GOING TO THE BASKET  
(THE SQUARED BOXES DISPLAY 3'S PASSING PROGRESSIONS)